

(19)  **Europäisches Patentamt**
European Patent Office
Office européen des brevets



(11) **EP 1 074 832 A1**

(12) **EUROPEAN PATENT APPLICATION**

(43) Date of publication:
07.02.2001 Bulletin 2001/06

(51) Int. Cl.⁷: **G01N 27/327, C12Q 1/00**

(21) Application number: **00114995.4**

(22) Date of filing: **21.07.2000**

(84) Designated Contracting States:
AT BE CH CY DE DK ES FI FR GB GR IE IT LI LU
MC NL PT SE
Designated Extension States:
AL LT LV MK RO SI

- **Noell, Oakey J.**
Granger, Indiana 46530 (US)
- **Edelbrock, Andrew J.**
Granger, Indiana 46530 (US)

(30) Priority: **02.08.1999 US 366269**

(74) Representative:
Burkert, Frank et al
Bayer AG,
Konzernbereich RP
Patente und Lizenzen
51368 Leverkusen (DE)

(71) Applicant: **Bayer Corporation**
Pittsburgh, PA 15205-9741 (US)

(72) Inventors:
• **Musho, Matthew K.**
Granger, Indiana 46530 (US)

(54) **Improved electrochemical-sensor design**

(57) Disclosed is an improved electrochemical sensor having a base bearing a working and reference electrode which provides a flow path for a fluid test sample. The working electrode has a reaction layer on its surface which contains an enzyme capable of reacting with an analyte to produce electrons which are received by the working electrode. The base is mated with a cover to form a capillary space into which the test fluid is drawn. The improvement involves configuring the working and reference electrodes so that a major portion of the reference electrode is located downstream on the flow path from the working electrode with the exception of a small sub-element of the reference electrode which is in electrical communication with the primary portion of the reference electrode and located upstream of the working electrode. This configuration provides the sensor with the capability of sending a greatly reduced electrical signal to the device's detecting element in the event that the capillary space is incompletely filled with test fluid. This reduced signal can be manipulated to produce an error signal which affirmatively apprises the device's user that such incomplete filling has occurred.

EP 1 074 832 A1

BEST AVAILABLE COPY

Description**Background of the Invention**

[0001] The present invention relates to an electrochemical biosensor that can be used for the quantitation of a specific component (analyte) in a liquid sample. Electrochemical biosensors of the type under consideration are disclosed in U.S. Patent Nos. 5,120,420 and 5,264,103. These devices have an insulating base upon which carbon electrodes are printed with the electrodes being covered with a reagent layer comprising a hydrophilic polymer in combination with an oxidoreductase specific for the analyte. These patents typically involve a spacer element, a generally U shaped piece and a cover piece, so that when the base, spacer element and cover piece are laminated together, there is created a capillary space containing the electrodes covered by the reagent layer. In addition to the oxidoreductase, there is included an electron acceptor on the reagent layer or in another layer within the capillary space. A hydrophilic polymer, e.g. carboxymethylcellulose, is used to facilitate the drawing of the aqueous test fluid into the capillary space.

[0002] In U.S. Patent 5,141,868 there is disclosed another sensor in which the electrodes are contained within a capillary space. This reference describes the method of preparing a sensor by mating the base and cover plates which are adhered to the base to form a capillary space into which a fluid test sample such as blood is drawn. An alternative to this design is disclosed in U.S. Patent 5,798,031 in which the sensor is comprised of two pieces, a base and a concave lid which, when fused together, form the capillary space. In either embodiment, working and reference electrodes are screen printed onto the base so that an electrochemically created current can flow when these electrodes are electrically connected and a potential created between them.

[0003] These devices have a base plate and lid which are laminated together with the U shaped spacer element in between so that the U shaped portion is open to provide a capillary space between the base and the cover. Touching the opening in the side of the sensor to a drop of test fluid such as blood results in the blood being drawn into the capillary space, so that it covers the reaction layer on the surface of the working electrode. An enzymatic reaction between the oxidoreductase creates a flow of electrons which are carried by a mediator such as ferricyanide to the working electrode and flow through the working electrode to a meter which measures the magnitude of the current flow. The reference electrode serves several purposes. First, it provides a fixed potential against which the working electrode is controlled. Second, for a two electrode system, such as that depicted in Figs. 1 and 2, the reference electrode is used to complete the electrical circuit. In this mode, each electron that is transferred to the

working electrode is returned to the test solution on the reference electrode side. The device's software is programmed to correlate the magnitude of this flow with the concentration of analyte in the test sample. In order for this current to flow, a complete circuit is formed by covering both electrodes with the conductive test fluid and applying a potential therebetween.

[0004] A problem which is sometimes associated with this sort of sensor occurs when an insufficient amount of blood is applied to the opening so that the reference and working electrodes are not completely covered with the sample, resulting in an incomplete current flowing across the electrodes. Since the amount of analyte such as glucose detected by the sensor is directly proportional to the current flowing through the detection meter, failure to completely cover the sensor's electrodes can result in an artificially low reading of the blood sample's glucose concentration. One technique for dealing with this under filling problem is disclosed in U.S. Patent 5,628,890 which involves a mechanism for preventing any response from being detected when the sample volume is too low to provide an accurate reading. This device involves a strip comprising an elongated electrode support defining a sample transfer path for directional flow of the sample from a sample application point. There is placed a working electrode in the sample transfer path and a counter or reference electrode down stream from the working electrode in the sample transfer path. Failure of the blood sample to totally cover the working electrode will result in no response from the reading mechanism due to the absence of a closed circuit through which current can flow.

[0005] It would be desirable and it is an object of the present invention to provide an electrochemical sensor which affirmatively notifies the user when insufficient sample has contacted the electrodes. Upon receiving such a notice the user knows that an accurate reading cannot be obtained and that the sensor should be discarded in favor of a new one.

Summary of the Invention

[0006] The present invention is an electrochemical sensor for detecting the concentration of an analyte, e.g. glucose, in a fluid test sample, such as blood. The sensor comprises:

- 1) a base which provides a flow path for the fluid test sample having on its surface a reference electrode and a working electrode in electrical communication with a detector of electrical current,
- 2) a reaction layer on the surface of the working electrode which contains an enzyme which reacts with the analyte to produce electrons that are transferred to the working electrode, and

BEST AVAILABLE COPY

3) a cover which when mated with the base member forms a capillary space with an opening for the introduction of fluid test sample into this space. The capillary space encloses the flow path for the fluid test sample in which the reference and working electrodes are contained. These electrodes are situated on the base in relation to the opening so that a major portion of the reference electrode is located downstream of the opening from the working electrode. The reference electrode contains a sub-element which is located upstream of the working electrode, so that when electrical communication between only the sub-element of the reference electrode and working electrode due to incomplete filling of the capillary space by the fluid test sample occurs, there is insufficient flow of electrical current through the detector to constitute a valid test for the concentration of analyte in the fluid test sample. In the event of such insufficient flow of electrical current, the detector gives an error signal to notify the user that the test has failed and that it should be repeated.

Brief Description of the Drawing

[0007]

Fig. 1 represents an exploded view of the sensor of the present invention.

Fig. 2 represents the sensor's base and those elements of the sensor which are applied directly to the base.

Description of the Invention

[0008] The construction of the electrochemical sensor with which the present invention is concerned is illustrated by Fig. 1. The sensor 34 is made up of insulating base 36 upon which is printed in sequence (typically by screen printing techniques) an electrical conductor pattern 38, an electrode pattern (39 and 40) an insulating (dielectric) pattern 42 and finally a reaction layer 44. The function of the reaction layer is to convert glucose, or another analyte in the fluid test sample, stoichiometrically into a chemical species which is electrochemically measurable, in terms of electrical current it produces, by the components of the electrode pattern. The reaction layer typically contains an enzyme which reacts with the analyte to produce mobile electrons on the electrode pattern and an electron acceptor such as a ferricyanide salt to carry the mobile electrons to the surface of the working electrode. The enzyme in the reaction layer can be combined with a hydrophilic polymer such as poly(ethylene oxide). The two parts 39 and 40 of the electrode print provide the working 39 and reference 40 electrodes necessary for the electrochemical determination of the analyte which is the crux of the

present invention. The working and reference electrodes are configured in a manner such that the major portion of the reference electrode is located downstream (in terms of the direction of fluid flow along the flow path) from the exposed portion of the working electrode 39a. This configuration offers the advantage of allowing the test fluid to completely cover the exposed portion of the working electrode for all cases in which an undetected partial fill has occurred. However, sub-element 40a of the reference electrode is positioned upstream from working electrode upper element 39a so that when an inadequate amount of fluid such as blood to completely cover the working electrode enters the capillary space there will be formed an electrical connection between reference electrode sub-element 40a and exposed portion of the working electrode upper part 39a due to the conductivity of the blood sample. However, the area of the reference electrode which is available for contact by the blood sample is so small that only a very weak current can pass between the electrodes and hence through the current detector. By programming the current detector to give an error signal when the signal it receives is below a certain pre-determined level, the sensor device of the present invention actively advises the user that insufficient blood has entered the sensor's cavity and that another test should be conducted. While the particular dimensions of the electrodes are not critical, the area of the sub-element of the reference electrode is typically less than about 10% than that of the working electrode and preferably less than about 6%. This element is made as small as possible in view of the restraints of the screen printing process. It is also contemplated that reaction layer 44 can be removed from contact with sub-element 40a of the counter electrode. This is accomplished by producing a screen that does not print reagent ink over the reference electrode sub-element 40b and serves the purpose of starving the sub-element for reagent thereby not allowing it to function as a proper reference electrode, so that an error condition is achieved in the case of failure of the test fluid to contact the bulk of the reference electrode 40. While sub-element 40a is depicted as being physically connected to, and therefore part of, the reference electrode 40, such physical connection is not critical. Such sub-element can be physically disconnected from the rest of the reference electrode provided that it is provided with its own connector and the sensor is equipped with a third contact to the detector.

[0009] The two parts 39 and 40 of the printed electrode provide the working and reference electrodes necessary for the electrochemical determination of analyte. The electrode ink, which is about 14 μ (0.00055") thick, typically contains electrochemically active carbon. Components of the conductor ink are a mixture of carbon and silver which is chosen to provide a low chemical resistance path between the electrodes and the meter with which they are in operative connection via contact with the conductive pattern at the fish-tail end of

BEST AVAILABLE COPY

the sensor 45. The reference electrode can be comprised of silver/silver chloride although carbon is preferred. The function of the dielectric pattern is to insulate the electrodes from the fluid test sample except in a defined area near the center of the electrode pattern to enhance the reproducibility of the meter reading. A defined area is important in this type of electrochemical determination because the measured current is dependent both on the concentration of the analyte and the area of the reaction layer which is exposed to the analyte containing test sample. A typical dielectric layer 42 comprises a UV cured acrylate modified polymethane which is about 10 μ (0.0004") thick. The lid 46 which provides a concave space 48, and which is typically formed by embossing a flat sheet of deformable material, is punctured to provide air vent 50 and joined to the base 36 in a sealing operation. The lid and base can be sealed together by sonic welding in which the base and lid are first aligned and then pressed together between a vibratory heat sealing member or horn and a stationary jaw. The horn is shaped such that contact is made only with the flat, non-embossed regions of the lid. Ultrasonic energy from a crystal or other transducer is used to excite vibrations in the metal horn. This mechanical energy is dissipated as heat in the plastic joint allowing the bonding of the thermoplastic materials. The embossed lid and base can also be joined by use of an adhesive material on the underside of the lid. The method of joining the lid and base are more fully described in U.S. Patent 5,798,031 which is incorporated herein by reference.

[0010] Suitable materials for the insulating base include polycarbonate, polyethylene terephthalate and dimensionally stable vinyl and acrylic polymers as well as polymer blends such as polycarbonate/polyethylene terephthalate and metal foil structures such as a nylon/aluminum/polyvinyl chloride laminate. The lid is typically fabricated from a deformable polymeric sheet material such as polycarbonate or an embossable grade of polyethylene terephthalate, glycol modified polyethylene terephthalate or a metal foil composition such as an aluminum foil structure. The dielectric layer can be fabricated from an acrylate modified polyurethane which is curable by UV light or moisture or a vinyl polymer which is heat curable.

[0011] The construction of a sensor according to the present invention is accomplished according to the following example:

Example I

[0012] The base stock, typically of polycarbonate, is printed with various inks to form the electrodes 39 and 40 and then overcoated with a dielectric layer 42 in a predetermined pattern designed to leave a desired surface of the electrode exposed to contact by the fluid test sample as it enters the space formed by the mating of lid 46 and base 36. The particular configuration of the

dielectric layer 42 as depicted in Fig. 1 in which opening 43 leaves the reagent layer in electrical communication with the electrodes 39 and 40 is designed to define the extent to which all of the conductive elements (working, reference and sub-element electrodes) are exposed to the test fluid. Along with the printed conductive features, the dielectric layer defines the size of each of these elements. The electrodes are preferably printed so that the conductive and dielectric layers are close to 90 degrees to each other. This helps in the tolerance stackup for building the sensor because it reduces the registration issues since as either printing shifts around the element, definition remains constant. The sensor base of the present invention is also illustrated in Fig. 2 in which all elements on the base are shown in the same plane. The sensor's base 36 has conductive element 38 on its surface which is in turn overcoated with working electrode 39 and reference electrode 40. Dielectric layer 42 is not shown but instead the opening 43 in the dielectric layer is shown to illustrate the portions of working electrode 39 and reference electrode 40 which are exposed. The sub-element of the reference electrode which is in electrical communication with the larger portion of the reference electrode, designated as 40b, functions in this embodiment to provide an electrical conduction path with the working electrode such that the fluid can be detected as having reached the working electrode. Sufficient current will be provided to initiate the test sequence. If the test fluid fails to fill the sensor cavity and contact the major portion of the reference electrode, an error condition will be detected and communicated to the user of the device.

[0013] A large number of sensors according to the present invention are fabricated from a rolled sheet of polycarbonate which has been unrolled to provide a flat surface. This sheet is referred to as the lid stock since it serves as the source for a multiplicity of lids. There is typically placed a layer of thermoplastic adhesive on the underside of the lidstock after which concave areas 48 (Fig. 1) are embossed into the polycarbonate sheet and various holes are punched into the sheet to provide vent holes 50 and for registration and tracking before slit ribbons of lidstock are rolled up. The base stock, typically of polycarbonate, is printed with various inks to form the electrodes and then overcoated with the dielectric layer in a predetermined pattern designed to leave a desired surface of the electrode exposed to the reaction layer 44 when it is printed over the dielectric layer.

[0014] The present invention introduces the advantage of providing an electrochemical sensor in which the reference and working electrodes can be configured so that in the event of a short fill, the result will be affirmative as opposed to a neutral response, i.e. a failure of the detector to give any signal. Thus, when the amount of test fluid which enters the capillary space is sufficient to cover the sub-element of the reference electrode 40a, or 40b in the preferred embodiment, and that portion of the working electrode 39a which lies upstream from the

BEST AVAILABLE COPY

main portion of the reference electrode 40, the detector will sense a current but the current will be weaker than would be the case if the working and reference electrodes were completely covered with the test fluid. The detector can be connected with the reading means to provide an error signal which will alert the user to the occurrence of a short fill. There are provided means for sensing certain characteristics of the current over time that are used along with the absolute current level to determine if an error condition has occurred. This is accomplished by algorithmically programming the meter to detect the short fill by measuring the current at a definite time period, after the test fluid has electrically connected the sub-element of the reference electrode with the working electrode. The ratio of the currents for the two measurements is used to determine if the sensor has filled properly. For example, the current is measured at 5 and 10 seconds after the application of the driving potential to the circuit, and these two currents are converted into a ratio. This ratio and the current reading at 10 seconds are used to determine if the sensor's capillary space has filled properly. A sample calculation is as follows: Three current measurements are made during the test sequence: 1) at the end of an initial period known as burn-off in which the driving potential has been applied for 10 seconds denoted as I_{r10} ; 2) at the 5 seconds during the second period known as the read period when the potential is applied denoted as I_{r5} ; and 3) at the end of the read period denoted as I_{r10} . See Figure 1. Two parameters are determined from the three current measurements. These two parameters are used to determine if the sensor's capillary space has filled properly. The first parameter is the decay factor, which describes the shape of current time course. The second parameter is a ratio that characterizes the rate of decay in the current level during the read phase. The decay factor, k , is defined as:

$$k = \frac{\ln(I_{r5}) - \ln(I_{r10})}{\ln(10) - \ln(5)} \quad \text{Eq. 1}$$

The Read-to-Burn ratio, R/B is defined as:

$$R/B = I_{r10} / I_{b10} \quad \text{Eq. 2}$$

The criteria for a short fill using these parameters are:

- (1) If $k < 0.227$ or $k > 0.497$; or
- (2) If $R/B < 0.263$ or $R/B > 1.263$.

A sample calculation is as follows:

An under-filled sensor produced the following three current measurements:

$$I_{b10} = 505.1 \text{ nA}, \quad I_{r5} = 656.5 \text{ nA}, \quad \text{and} \\ I_{r10} = 561.8 \text{ nA}.$$

The decay factor and Read-to-Burn ratio were calculated from the current measurements:

Decay factor

[0015]

$$k = \frac{\ln(I_{r5}) - \ln(I_{r10})}{\ln(10) - \ln(5)} = \frac{\ln(656.5) - \ln(561.8)}{\ln(10) - \ln(5)} = 0.22$$

Read-to-Burn ratio

[0016]

$$R/B = I_{r10} / I_{b10} = 561.8 / 505.1 = 1.11$$

These two parameters were used to detect the following error conditions:

- $k < 0.227$ or $k > 0.497$ at this glucose readback level. True because $k = 0.22 < 0.227$;
- $R/B < 0.263$ or $R/B > 1.263$ at this glucose readback level. False because $R/B = 1.11 > 0.263$ and < 1.263 .

[0017] By providing a device which gives a positive (as opposed to a neutral) response in the event of a short fill, the user will recognize that the abortive function of the test is a result of too little blood entering the capillary space rather than some other malfunction having caused the anomalous result.

Claims

1. An electrochemical sensor for detecting the concentration of analyte in a fluid test sample which comprises: 1) a base which provides a flow path for the fluid test sample having on its surface a reference electrode and a working electrode in electrical communication with a detector of electrical current; 2) a reaction layer on the surface of the working electrode comprising an enzyme which reacts with the analyte to produce electrons that are transferred to the working electrode; and 3) a cover which when mated with the base member forms a capillary space with an opening for the introduction of fluid test sample thereto which space contains the flow path for the fluid test sample in which the reference and working electrodes are situated so that the major portion of the reference electrode is located downstream of the opening from the working electrode with a sub-element of the reference electrode being upstream of the working electrode so that when electrical communication between only the sub-element and working electrode takes place there is insufficient flow of electrical current through the detector to constitute a valid test for the

BEST AVAILABLE COPY

concentration of analyte in the fluid test sample and the detector is pre-programmed to emit an error signal in the event of such insufficient flow of electrical current.

5

2. The sensor of Claim 1 wherein the reference electrode and the sub-element are physically connected.

3. The sensor of Claim 1 wherein the cover is made of a deformable material which is deformed to provide a concave area in the central portion thereof such that when the cover is mated with the base member the cover and the base member form the capillary space with the opening therein.

15

4. The sensor of Claim 1 wherein the opening to the capillary space is solely through the cover or the base member.

20

5. The sensor of Claim 4 wherein the opening is solely through the cover.

6. The sensor of Claim 1 wherein the base and cover are configured to form the opening when they are mated.

25

7. The sensor of Claim 6 wherein the cover is concave and the opening is formed by mating the based with the concave cover.

30

8. The sensor of Claim 1 wherein the enzyme is glucose oxidase.

9. The sensor of Claim 1 wherein a major portion of the working electrode is covered by a dielectric material leaving a minor portion of it exposed to the test fluid and the major portion of the reference electrode is located downstream (in terms of the direction of fluid flow along the flow path) from the exposed portion of the working electrode.

35

40

10. The sensor of Claim 1 wherein the sub-element of the reference electrode is not physically connected to the main element of the reference electrode and the sub-element is connected to the detector by its own connecting element.

45

50

55

BEST AVAILABLE COPY

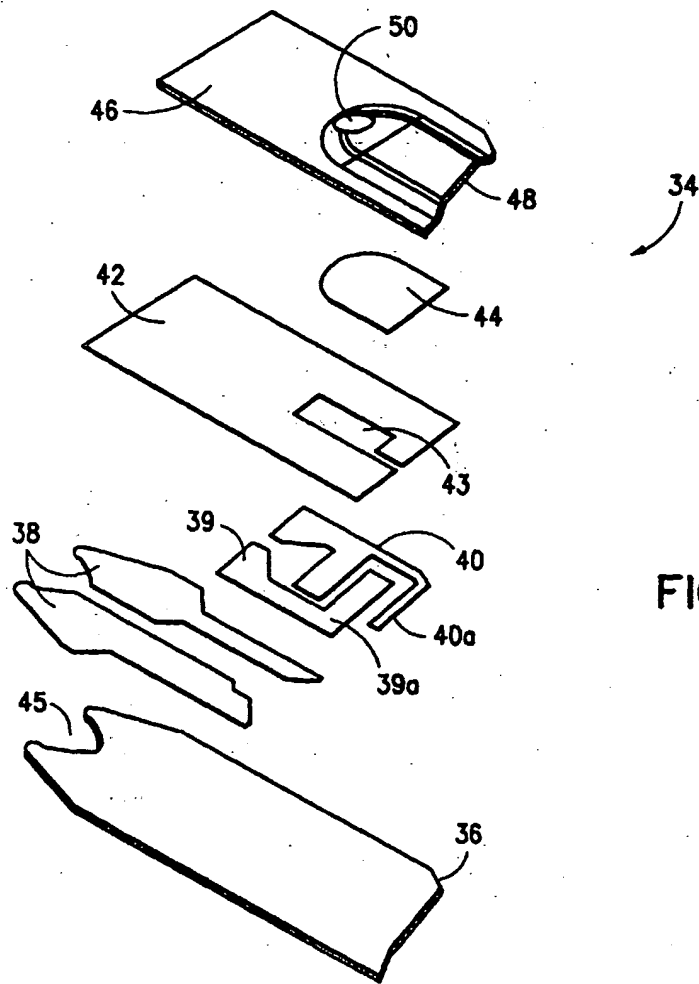

FIG. 1

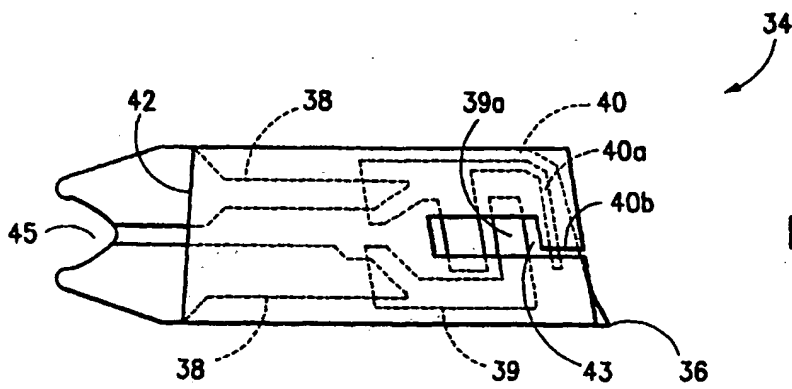

FIG. 2

BEST AVAILABLE COPY



European Patent
Office

EUROPEAN SEARCH REPORT

Application Number
EP 00 11 4995

DOCUMENTS CONSIDERED TO BE RELEVANT			
Category	Citation of document with indication, where appropriate, of relevant passages	Relevant to claim	CLASSIFICATION OF THE APPLICATION (Int.Cl.7)
X	EP 0 732 406 A (MATSUSHITA ELECTRIC IND CO LTD) 18 September 1996 (1996-09-18) * column 3, line 17 - line 39 * * column 4, line 21 - line 43 * * column 6, line 24 - line 55 * * column 8, line 19 - column 9, line 9 * * figures *	1,3-10	601N27/327 C12Q1/00
X	EP 0 735 363 A (MATSUSHITA ELECTRIC IND CO LTD) 2 October 1996 (1996-10-02) * column 3, line 26 - line 39 * * column 7, line 19 - line 26 * * figures 2,5 *	1,3-10	
A	EP 0 851 224 A (MATSUSHITA ELECTRIC IND CO LTD) 1 July 1998 (1998-07-01) * claim 1 * * figure 2 *	1-10	
A	DE 197 47 875 A (KNOLL MEINHARD PROF DR) 6 May 1999 (1999-05-06) * figure 1 *	1	
			TECHNICAL FIELDS SEARCHED (Int.Cl.7)
			C12Q G01N C12M
The present search report has been drawn up for all claims			
Place of search		Date of completion of the search	Examiner
THE HAGUE		15 November 2000	Muñoz, M
CATEGORY OF CITED DOCUMENTS			
X: particularly relevant if taken alone Y: particularly relevant if combined with another document of the same category A: technological background O: non-written disclosure P: intermediate document		T: theory or principle underlying the invention E: earlier patent document, but published on, or after the filing date D: document cited in the application L: document cited for other reasons &: member of the same patent family, corresponding document	

EPO FORM 1503 03/82 (P04/01)

BEST AVAILABLE COPY

ANNEX TO THE EUROPEAN SEARCH REPORT
ON EUROPEAN PATENT APPLICATION NO.

EP 00 11 4995

This annex lists the patent family members relating to the patent documents cited in the above-mentioned European search report. The members are as contained in the European Patent Office EDP file on
The European Patent Office is in no way liable for these particulars which are merely given for the purpose of information.

15-11-2000

Patent document cited in search report		Publication date	Patent family member(s)	Publication date
EP 0732406	A	18-09-1996	CA 2153350 A	18-09-1996
			JP 8320304 A	03-12-1996
			US 5582697 A	10-12-1996
			US 5650062 A	22-07-1997
EP 0735363	A	02-10-1996	DE 69221808 D	02-10-1997
			DE 69221808 T	02-04-1998
			EP 0537761 A	21-04-1993
			JP 2960265 B	06-10-1999
			JP 5340915 A	24-12-1993
			US 5264103 A	23-11-1993
			JP 2658769 B	30-09-1997
EP 0851224	A	01-07-1998	JP 10185860 A	14-07-1998
			US 5985116 A	16-11-1999
DE 19747875	A	06-05-1999	WO 9920999 A	29-04-1999

BEST AVAILABLE COPY

This Page Blank (uspto)